

# FELUN-HEL-FATO-N-C

## Autonomous helipad lighting system



ICAO Compliant Equipment Annex 14 Volume 1 - FAA compliant equipment.



### APPLICATION

FATO helipad elevated light, ICAO compliant.

The FELUN® is an autonomous battery powered light equipped with solar panels. It is also radio-controlled and designed for permanent or mobile usage.

### MAIN CHARACTERISTICS

- Great autonomy up to 216h
- High performance integrated directive antenna
- Resin-coated electronics (IP68)
- Sturdy and reliable, designed to reduce and simplify maintenance

### PHOTOMETRY

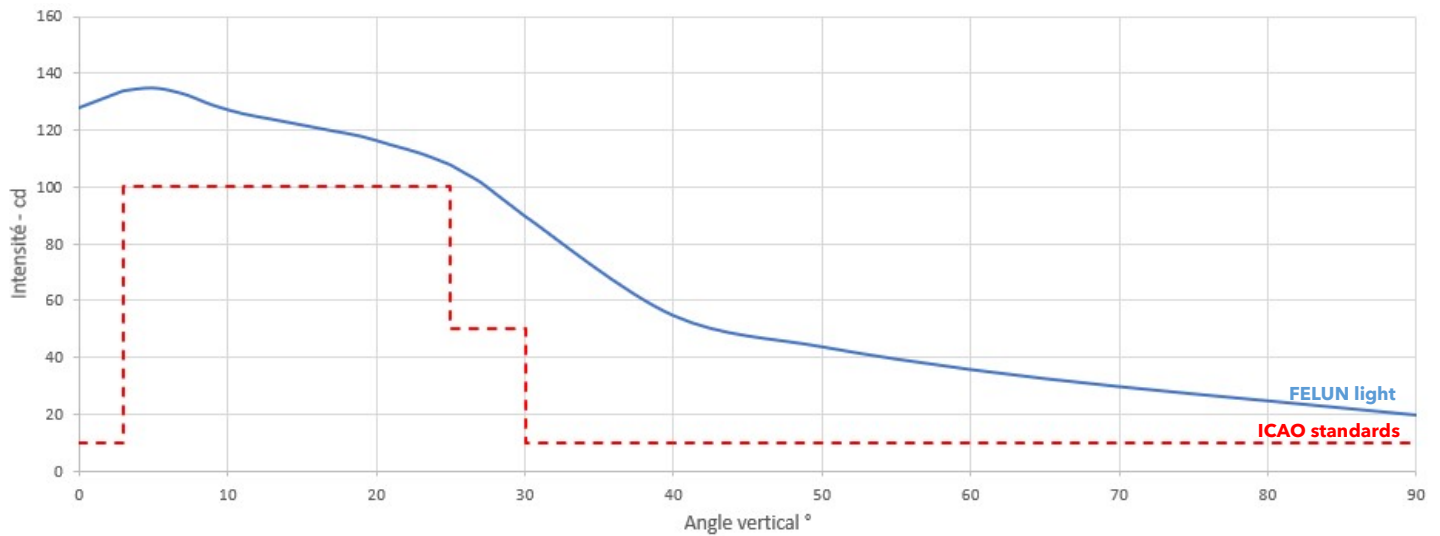

### ORDER CODE

FELUN-HEL-FATO-N-C - **A** - **A** - **A** - **A**

Battery	Solar panels	GPS	Magnetic mounting
A 17A.h battery	A 4 panels 2W kit	A With GPS	A With magnetic mounting
B 24A.h battery	N No panel	N No GPS	N No magnetic mounting

The light mounting accessories are available in the FIX documentation.  
Control systems are available on the CAESAR documentation.

## OVERVIEW

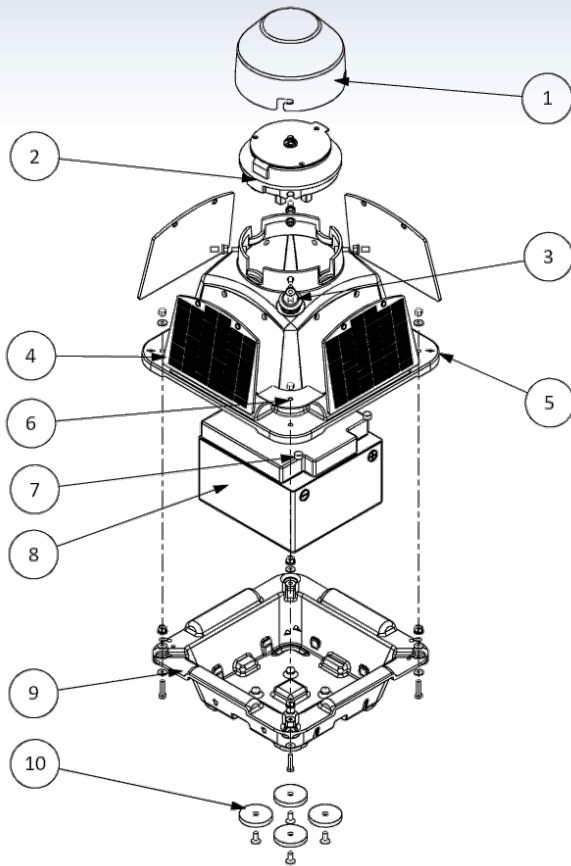

1. Optical glass
2. Resin-coated electronics
3. Push button
4. Solar panel
5. Body
6. Identification plate
7. Battery protection covers
8. 12V Battery
9. Base
10. Mounting magnets

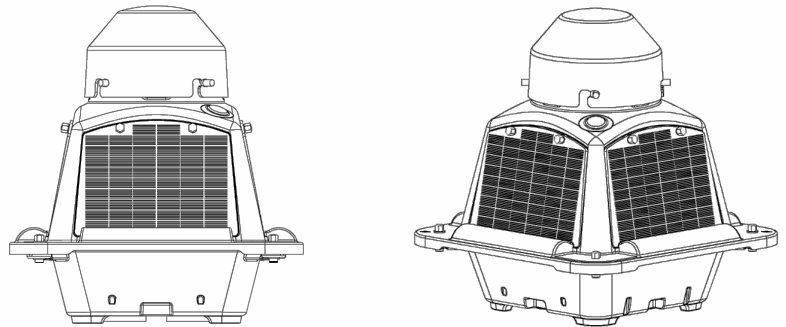

## TECHNICAL SPECIFICATIONS

### OPTIC

- Green color, 360° omnidirectional beam
- Three levels of brightness
- LED technology, LED lifespan 100 000 h
- User-replaceable light source
- Infrared light source (NVG) optional

### CONFORMITY

- ICAO compliant Annex 14 Volume July 2018
- STAC certification pending
- CE compliant
- ISO 9001 and ISO 14001 design and manufacturing

### ENVIRONMENT

- Operating temperature : -20°C to +60°C
- Resin-coated electronics IP68

### RADIO

- Zigbee Mesh network 868Mhz
- High performance integrated directive antenna (Gmax 2.48dB)
- Operating range: 2km from control tower, 500m between lights

### ENERGY

- Beacon consumption:
  - Sleep mode (stocking): 0,006W
  - Running mode, light off: 0,2W
  - Running mode, lights on: 1,2W
- VRLA 12V battery, lifespan 10-12 years (EUROBAT), Temperature range -20°C to +60°C
  - Model A: 17A.h (204Wh)
  - Model B: 24A.h (288Wh)
- Polycrystalline solar panels 4x2W
- On station charge : tension 8V-24Vdc, fast charging 50Wh

### AUTONOMY

	Bat 17A.h*	Bat 24A.h*
Lamp turned off	42 jrs	60 jrs
Lamp turned on	6,5 jrs	9 jrs
Daily usage 4h on / 20h off	22 jrs	31 jrs

### PHYSICAL CHARACTERISTICS

- UV resistant polyethylene body (20 years of lifetime)
- PMMA dome (UV insensitive)
- Light magnetic fixation on galvanized metallic plate  
See doc FIX for more information
- Dimensions (l x w x h): 295 x 295 x 318mm
- Weight: 8,8Kg (battery model A) / 11,7Kg (battery model B)

\* Without power from solar panels