

FELUN-RWY-THEND-LI-GR

Autonomous lighting system



ICAO Compliant Equipment Annex 14 Volume 1 - FAA compliant equipment.



APPLICATION

Low intensity green/red omnidirectional runway threshold/end light, compliant with non precision approach usage.

The FELUN® is an autonomous battery powered light equipped with solar panels. It is radio-controlled and designed for permanent or mobile usage.

PHOTOMETRY

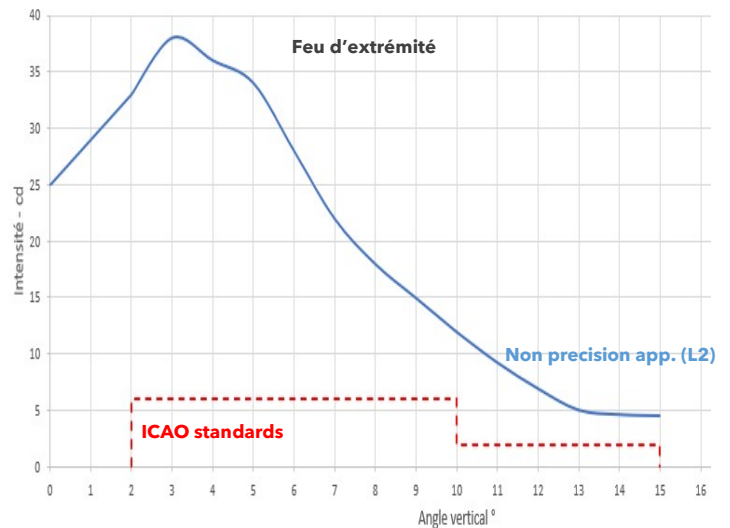
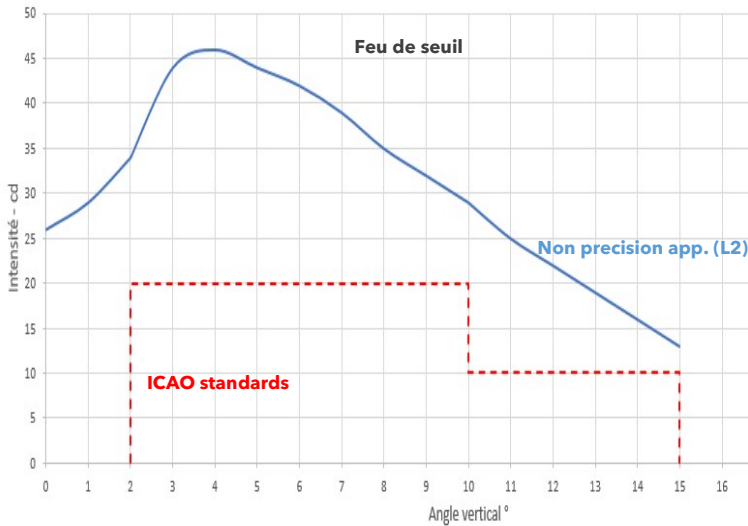

ORDER CODE

FELUN-RWY-THEND-LI-GR - **A** - **A** - **A** - **A**

Battery	Solar panels	GPS	Magnetic mounting
A 17A.h battery	A 4 panels 2W kit	A With GPS	A With magnetic mounting
B 24A.h battery	N No panel	N No GPS	N No magnetic mounting

The light mounting accessories are available in the FIX documentation.
Control systems are available on the CAESAR documentation.

OVERVIEW

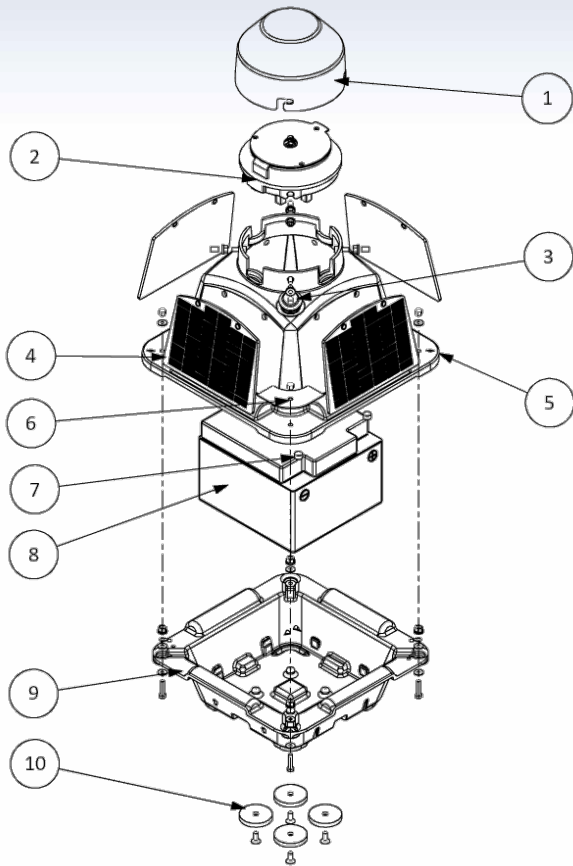

1. Optical glass
2. Resin-coated electronics
3. Push button
4. Solar panel
5. Body
6. Identification plate
7. Battery protection covers
8. 12V Battery
9. Base
10. Mounting magnets

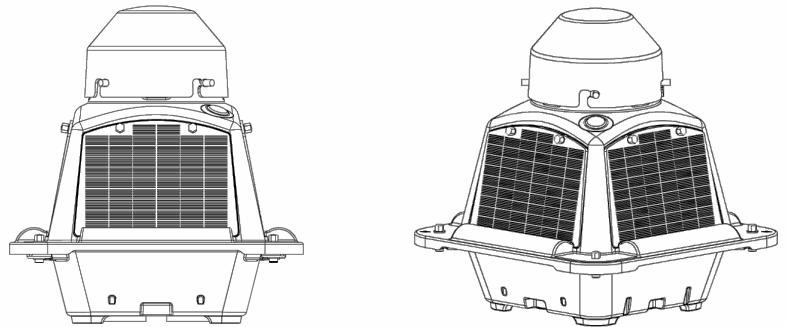

TECHNICAL SPECIFICATIONS

OPTIC

- Green/red color, 360° omnidirectional beam
- Five levels of brightness (L1 to L5)
 - L1: Visual approach (TH avg>15cd, End avg>5cd)
 - L2: non precision approach (TH avg>30cd, End avg>10cd)
 - L3 to L5: avg > 45/20cd, 55/30cd, 65/40cd
- LED technology, LED lifespan 100 000 h
- User-replaceable light source
- Infrared light source (NVG) optional

CONFORMITY

- Compliant in non precision approach according to ICAO Annex 14 Volume July 2018
- STAC certified N° 2021-067_AER (-20°C to +55°C)
- CE compliant
- ISO 9001 and ISO 14001 design and manufacturing

ENVIRONMENT

- Operating temperature : -20°C to +60°C
- Resin-coated electronics IP68

RADIO

- Zigbee Mesh network 868Mhz
- High performance integrated directive antenna (Gmax 2.48dB)
- Operating range: 2km from control tower, 500m between lights

ENERGY

- Beacon consumption:
 - Sleep mode (stocking): 0,006W
 - Running mode, light off: 0,2W
 - L1 / L2 / L3 / L4 / L5: 1,2W / 2,25W / 3,2W / 3,8W / 4,3W
- VRLA 12V battery, lifespan 10-12 years (EUROBAT), Temperature range -20°C to +60°C
 - Model A: 17A.h (204Wh)
 - Model B: 24A.h (288Wh)
- Polycrystalline solar panels 4x2W
- On station charge : tension 8V-24Vdc, fast charging 50Wh

AUTONOMY

	Bat 17A.h*	Bat 24A.h*
Lights off	42 jrs	60 jrs
Brightness L1	7 jrs	10 jrs
Brightness L2	3,7 jrs	5,3 jrs
Daily usage 4h L2 / 20h off	15,5 jrs	22 jrs

PHYSICAL CHARACTERISTICS

- UV resistant polyethylene body (20 years of lifetime)
- PMMA dome (UV insensitive)
- Light magnetic fixation on galvanized metallic plate
See doc FIX for more information
- Dimensions (l x w x h): 295 x 295 x 318mm
- Weight: 8,8Kg (battery model A) / 11,7Kg (battery model B)

* Without power from solar panels